

(19)



Europäisches Patentamt
European Patent Office
Office européen des brevets



(11)

EP 1 243 825 A1

(12)

EUROPEAN PATENT APPLICATION

(43) Date of publication:
25.09.2002 Bulletin 2002/39

(51) Int Cl.7: F16K 11/078, F16K 31/60,
F16K 35/04

(21) Application number: 02380061.8

(22) Date of filing: 18.03.2002

(84) Designated Contracting States:
AT BE CH CY DE DK ES FI FR GB GR IE IT LI LU
MC NL PT SE TR
Designated Extension States:
AL LT LV MK RO SI

(71) Applicant: Industrias Ramon Soler, S.A.
08970 Sant Joan Despi (ES)

(72) Inventor: Ferret Picazo, Xavier
08970 Sant Joan Despi (ES)

(30) Priority: 22.03.2001 ES 200100677

(74) Representative: Ponti Sales, Adelaida et al
Consell de Cent 322
08007 Barcelona (ES)

(54) **Mixing valve with flow regulation device**

(57) It includes a fixed ceramic disc (2) and a movable ceramic disc (3) housed inside a housing (1), the fixed disc (2) including a pair of cold and hot water inlet openings and an outlet opening (6) for the mixture of water, while the movable disc (3) includes a distribution opening (7), the movable disc (3) being attached to an actuating lever (4), including elastic means (8, 9) which limit actuation of said lever (4) to a certain position, in

which the output flow of water is limited to a set value, while the lever (4) can be placed in a second position for output of the maximum flow against the action of said elastic means (8, 9), and it is characterised in that said elastic means (8, 9) for limiting actuation of the lever are mounted in detachable manner around said lever (4).

The limiting means can be removed or replaced easily whenever the user so wishes.

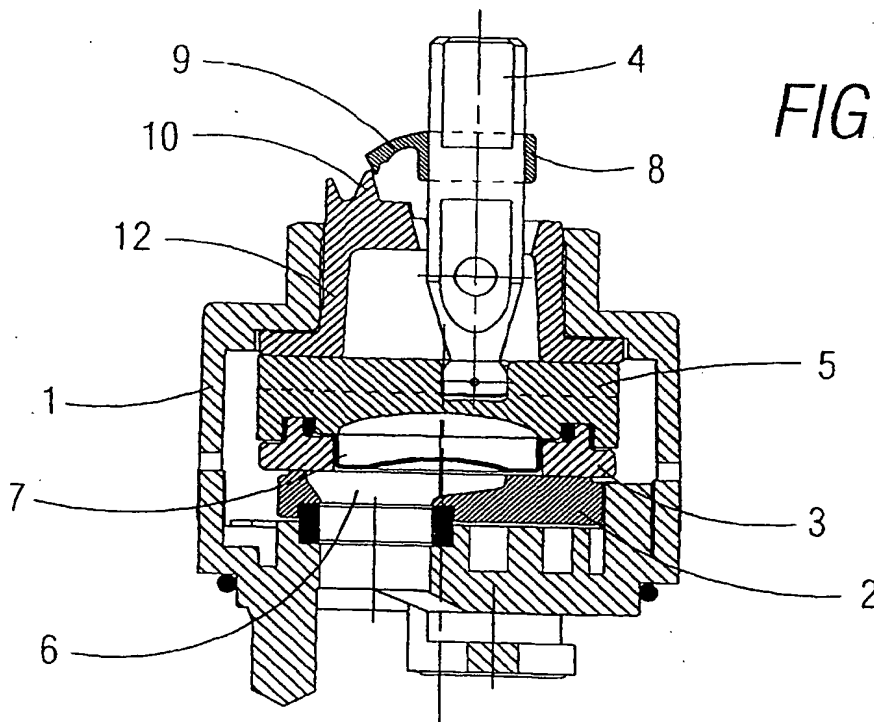

FIG. 1

EP 1 243 825 A1

Description

[0001] This invention relates to a fluids mixer valve with flow regulation which permits the flow of water to be regulated by means of a predetermined opening position and, if wished, permits maximum flow to be achieved.

[0002] The currently known mixer valves of single-lever type are made up of:

- a fixed ceramic disc provided with an orifice for the entry of cold water, an orifice for the entry of hot water and an orifice for output of the mixed water;
- a movable ceramic disc provided with a distribution opening, with the position of said movable disc with respect to the fixed disc determining the temperature of the water which flows from the valve and its flow; and
- an actuating lever attached to the movable disc, through which is actuated the movement of the movable disc.

[0003] Through said actuating lever the user can determine the desired degree of mixing of the hot and cold water and the flow of water, depending on the use being made at that time.

[0004] The mixture of cold and hot water is determined by the angular position of the movable disc with respect to the fixed disc, and depends on the position of the distribution opening with respect to the cold and hot water inlet orifices. Thus, by turning the actuating lever the user can regulate the temperature of the water coming out of the valve.

[0005] The flow of water is determined by the relative position of the movable disc on the fixed disc, so that the distribution opening covers a smaller or larger surface area of the hot and cold water input orifices.

[0006] It has been found in practice, however, that users open the valve fully, making the water emerge at maximum flow in all cases. These means that unnecessary water expenditure occurs, since a smaller flow of water is sufficient in many cases, such as for washing the hands.

[0007] In order to solve these disadvantages, the holder of this application designed the mixer valve with flow limitation described in Spanish utility model U9903214. That utility model discloses four different embodiments, which have in common the characteristic that the means for limiting the movement of the actuating lever are elastic and fixed, that is, they cannot be removed at the wish of the user.

[0008] More specifically, in the embodiments shown in Figures 1 and 2 of said utility model, the elastic regulating means are mounted on the movable disc. In these embodiments, the limiting means have to be fitted when the valve is fitted.

[0009] In the embodiments shown in Figures 3 and 4 of said utility model, the elastic limiting means are

mounted on the actuating lever, but are not mounted in movable manner. Furthermore, the elastic part of said limiting means is mounted on the valve housing.

[0010] The mixer valve of this invention manages to resolve the aforesaid disadvantages, while presenting other advantages which will be described.

[0011] The fluids mixer valve of this invention is characterised in that said elastic means for limiting actuation of the lever are mounted in detachable manner around said lever.

[0012] Thanks to this characteristic, the limiting means can be removed easily whenever the user so wishes, to provide a valve without flow limitation. Moreover, in the event of deterioration of the elastic means they can be replaced conveniently.

[0013] According to a preferred embodiment of this invention, said elastic means are made up of a ring provided with a lug of elastic material, in such a way that in said first position the lug abuts against a projecting piece attached to the valve housing, and the lever can be moved into said second position against the action of said projecting piece.

[0014] For a better understanding of all that has been described in this specification some drawings are attached which, solely by way of example, show a practical case of embodiment of the mixer valve of this invention.

[0015] In said drawings, Figure 1 is an elevation view of the mixer valve of this invention in cross-section, with the actuating lever in the position which permits outlet of half the maximum flow; and

[0016] Figure 2 is an elevation view of the mixer valve of this invention in cross-section, with the actuating lever in the position which permits outlet of the maximum flow.

[0017] Figure 1 shows an embodiment of the mixer valve of the invention. As is known in the art and usual in all mixer valves of the single-lever type, the valve includes a housing 1 inside which are housed a fixed disc 2 and a movable disc 3. The mixer valve also includes an actuating lever 4 attached to the movable disc 3 through an additional piece 5 attached to the movable disc 3.

[0018] The position of the movable disc 3 determines the output flow of the water and the output temperature of the water. For this purpose, the fixed disc 2 includes a pair of cold and hot water inlet openings (not shown in the figure) and an outlet opening 6 for the mixture of water. The movable disc 3 includes a distribution opening 7. In this way, rotation of the movable disc 3 on the fixed disc 2 will determine the output temperature of the water, and lineal movement of the movable disc 3 on the fixed disc 2 will determine the output flow of the water.

[0019] According to the invention, the mixer valve includes elastic means for limiting the output flow of water. These elastic means are made up of a ring 8 mounted around said lever 4. This ring 8 includes a lug 9 of elastic material which abuts against a projecting piece 10 provided on a piece 12 attached to the housing 1 of the

valve, as shown in Figure 1.

[0020] The ring 8 is mounted detachably on the lever 4, so that if the user so wishes it can be removed manually in order to provide a valve without flow regulation.

[0021] When the ring 8 is placed in position and the lever 4 is actuated, there comes a moment when the lug 9 of said ring 8 comes into contact with the projecting piece 10 (Figure 1), limiting the output of water. Said position has been designed to correspond to approximately half of the maximum flow.

[0022] If it is desired for the maximum flow of water to emerge the user has to exercise greater pressure on the lever 4, in such a way that the lug 9, thanks to its elastic nature, cedes before the opposition of said projecting piece 10.

[0023] In order to return the lever 4 to its original position, that lever has to be actuated in the opposite direction, with substantially lower pressure being needed for said lug 9 to cede before the opposition of said projecting piece 10 in the opposite direction.

[0024] Despite the fact that reference has been made to one specific embodiment of the invention, it will be obvious to a person skilled in the art that the mixer valve disclosed allows of many variations and modifications, and that all the details mentioned can be replaced by others that are technically equivalent, without departing from the sphere of protection defined in the attached claims.

Claims

1. Fluids mixer valve with regulation of the output flow of the fluid, which includes a fixed ceramic disc (2) and a movable ceramic disc (3) housed inside a housing (1), the fixed disc (2) including a pair of cold and hot water inlet openings and an outlet opening (6) for the mixture of water, while the movable disc (3) includes a distribution opening (7), the movable disc (3) being attached to an actuating lever (4), including elastic means (8, 9) which limit actuation of said lever (4) to a certain position, in which the output flow of water is limited to a set value, while the lever (4) can be placed in a second position for output of the maximum flow against the action of said elastic means (8, 9), **characterised in that** said elastic means (8, 9) for limiting actuation of the lever (4) are mounted in detachable manner around said lever (4).
2. Mixer valve as claimed in Claim 1, **characterised in that** said elastic means are made up of a ring (8) provided with a lug (9) of elastic material, in such a way that in said first position the lug (9) abuts against a projecting piece (10) attached to the valve housing (1), and the lever (4) can be moved into said second position against the action of said projecting piece (10).

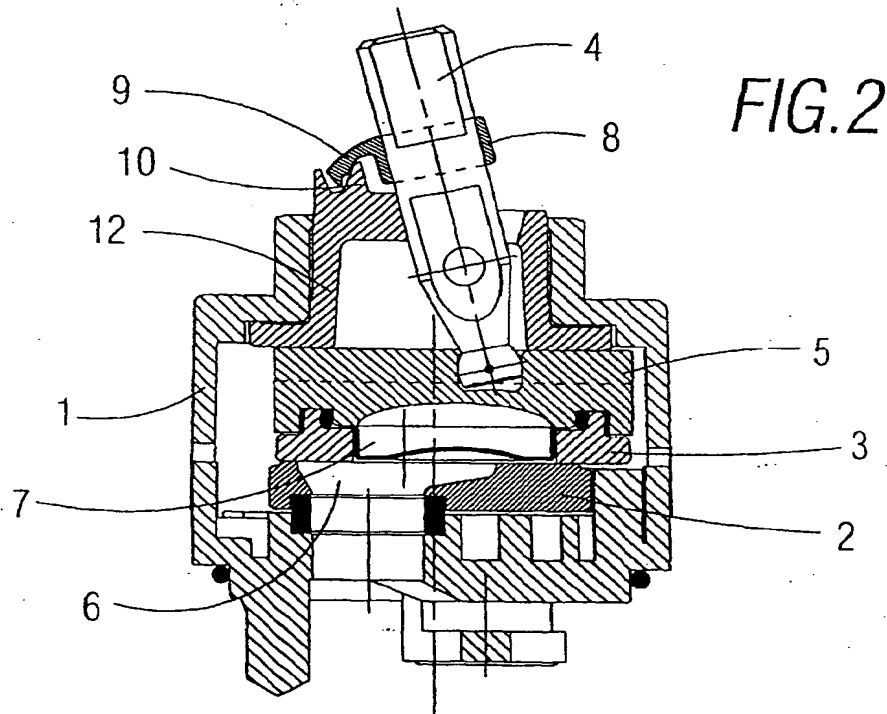
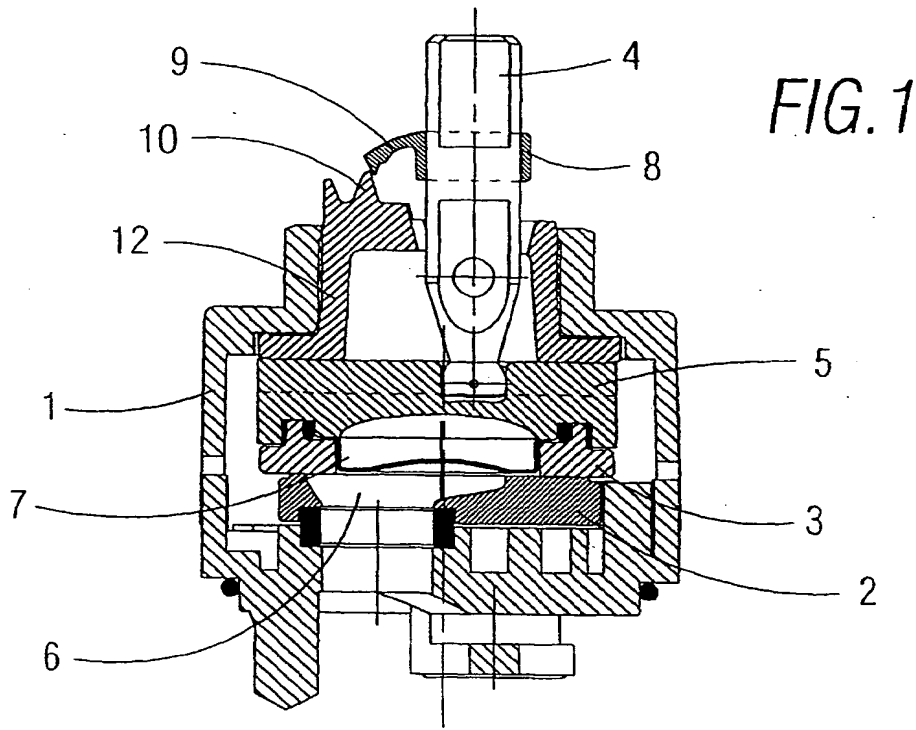



European Patent Office

EUROPEAN SEARCH REPORT

Application Number
EP 02 38 0061

DOCUMENTS CONSIDERED TO BE RELEVANT			
Category	Citation of document with indication, where appropriate, of relevant passages	Relevant to claim	CLASSIFICATION OF THE APPLICATION (Int.Cl.7)
X	WO 00 00765 A (KNAPP FRANCESCO ; MASCO CORP (US)) 6 January 2000 (2000-01-06) * page 3, line 12 - page 6, line 4 * * figures 1-4 *	1,2	F16K11/078 F16K31/60 F16K35/04
X	EP 1 020 671 A (NUOVA GALATRON S R L) 19 July 2000 (2000-07-19) * column 2, line 34 - column 3, line 20 * * figures 1-4 *	1,2	
X	EP 1 055 781 A (BOEHM HANS GEORG) 29 November 2000 (2000-11-29) * column 1, line 14 - line 30; figure 4 *	1,2	
X	EP 0 771 982 A (GALATRON SRL) 7 May 1997 (1997-05-07) * abstract; figures 1-7B *	1,2	
A	EP 0 309 443 A (IDEAL STANDARD) 29 March 1989 (1989-03-29) * column 4, line 23 - line 38 *	1,2	
A	EP 0 568 013 A (AMFAG SRL) 3 November 1993 (1993-11-03) * abstract; figures 3-6 *	1	
A	EP 0 643 246 A (ORAS OY) 15 March 1995 (1995-03-15) * abstract; figures 1-5 *	1	
A	DE 36 23 669 A (KNEBEL & ROETTGER FA) 28 January 1988 (1988-01-28) * figure 1 *	1	TECHNICAL FIELDS SEARCHED (Int.Cl.7) F16K
The present search report has been drawn up for all claims			
Place of search MUNICH		Date of completion of the search 6 June 2002	Examiner Awad, P
<p>CATEGORY OF CITED DOCUMENTS</p> <p>X : particularly relevant if taken alone Y : particularly relevant if combined with another document of the same category A : technological background O : non-written disclosure P : intermediate document</p> <p>T : theory or principle underlying the invention E : earlier patent document, but published on, or after the filing date D : document cited in the application L : document cited for other reasons & : member of the same patent family, corresponding document</p>			

EPO FORM 1503 03.82 (P04C01)

ANNEX TO THE EUROPEAN SEARCH REPORT
ON EUROPEAN PATENT APPLICATION NO.

EP 02 38 0061

This annex lists the patent family members relating to the patent documents cited in the above-mentioned European search report. The members are as contained in the European Patent Office EDP file on
The European Patent Office is in no way liable for these particulars which are merely given for the purpose of information.

06-06-2002

Patent document cited in search report		Publication date		Patent family member(s)	Publication date
WO 0000765	A	06-01-2000	IT	T0980550 A1	27-12-1999
			AU	4705599 A	17-01-2000
			BR	9911370 A	13-03-2001
			CA	2324144 A1	06-01-2000
			CN	1313939 T	19-09-2001
			EP	1088183 A1	04-04-2001
			TW	430726 B	21-04-2001
			WO	0000765 A1	06-01-2000
EP 1020671	A	19-07-2000	IT	BS990005 U1	17-07-2000
			EP	1020671 A2	19-07-2000
EP 1055781	A	29-11-2000	DE	19923899 A1	14-12-2000
			EP	1055781 A2	29-11-2000
EP 0771982	A	07-05-1997	IT	1281653 B1	20-02-1998
			AU	703798 B2	01-04-1999
			AU	7057696 A	08-05-1997
			EP	0771982 A1	07-05-1997
			NZ	299675 A	19-12-1997
			US	5899230 A	04-05-1999
EP 0309443	A	29-03-1989	AT	390490 B	10-05-1990
			AT	242887 A	15-10-1989
			WO	8903000 A1	06-04-1989
			AT	66292 T	15-08-1991
			CA	1293907 A1	07-01-1992
			DE	3864223 D1	19-09-1991
			DK	249589 A ,B,	23-05-1989
			EP	0309443 A1	29-03-1989
			FI	892471 A ,B,	22-05-1989
			JP	1142140 A	05-06-1989
			JP	2553160 B2	13-11-1996
			KR	9303050 B1	17-04-1993
			MX	171309 B	18-10-1993
			NO	892063 A ,B,	23-05-1989
US	4960154 A	02-10-1990			
EP 0568013	A	03-11-1993	IT	1260746 B	22-04-1996
			DE	69301496 D1	21-03-1996
			DE	69301496 T2	27-06-1996
			EP	0568013 A1	03-11-1993
			ES	2083221 T3	01-04-1996
			US	5386852 A	07-02-1995
EP 0643246	A	15-03-1995	FI	94167 B	13-04-1995

EPO FORM P0439

For more details about this annex : see Official Journal of the European Patent Office, No. 12/82

**ANNEX TO THE EUROPEAN SEARCH REPORT
ON EUROPEAN PATENT APPLICATION NO.**

EP 02 38 0061

This annex lists the patent family members relating to the patent documents cited in the above-mentioned European search report. The members are as contained in the European Patent Office EDP file on
The European Patent Office is in no way liable for these particulars which are merely given for the purpose of information.

06-06-2002

Patent document cited in search report	Publication date	Patent family member(s)	Publication date
EP 0643246 A		AT 145268 T	15-11-1996
		DE 69400898 D1	19-12-1996
		DE 69400898 T2	06-03-1997
		DK 643246 T3	28-04-1997
		EP 0643246 A1	15-03-1995
		ES 2094605 T3	16-01-1997
		NO 943403 A	15-03-1995
DE 3623669 A	28-01-1988	DE 3623669 A1	28-01-1988

FPO-HOHM-H0459

For more details about this annex : see Official Journal of the European Patent Office, No. 12/82

THIS PAGE BLANK (USPTO)